

The RF Line UHF Power Amplifiers

Designed for 7.5 Volt UHF power amplifier applications in industrial and commercial equipment primarily hand portable radios.

- MHW707-1, f = 403-440 MHz
- MHW707-2, f = 440-470 MHz
- MHW707-3, f = 470-500 MHz
- MHW707-4, f = 490-512 MHz
- Specified 7.5 Volt Characteristics:
 - RF Input Power = 1.0 mW (0 dBm)
 - RF Output Power = 7.0 Watts (2)
 - Minimum Gain ($V_{Control} = 7.0 V$) = 38.5 dB (2)
 - Harmonics = -40 dBc Max @ $2 f_0$
- 50 Ω Input/Output Impedance
- Guaranteed Stability and Ruggedness
- Epoxy Glass PCB Construction Gives Consistent Performance and Reliability
- Test fixture circuit board photomaster available upon request by contacting RF Tactical Marketing in Phoenix, AZ.

MHW707-1
MHW707-2
MHW707-3
MHW707-4

7.0 W, 403 to 500 MHz
6.5 W, 490 to 512 MHz
UHF POWER
AMPLIFIERS

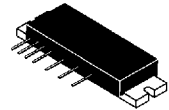

CASE 301J-04, STYLE 1

MAXIMUM RATINGS (Flange Temperature = 25°C)

Rating	Symbol	Value	Unit
DC Supply Voltage (Pins 2,4,5,6)	$V_{S1,2,3,4}$	9.0	Vdc
DC Control Voltage (Pin 3)	V_{Cont}	7.0	Vdc
RF Input Power	P_{in}	3.0	mW
RF Output Power ($V_{S1} = V_{S2} = V_{S3} = V_{S4} = 9.0 Vdc$)	P_{out}	9.0	W
Operating Case Temperature Range	T_C	-30 to +80	°C
Storage Temperature Range	T_{stg}	-30 to +80	°C

ELECTRICAL CHARACTERISTICS $V_{S1} = V_{S2} = V_{S3} = V_{S4} = 7.5 Vdc$, (Pins 2,4,5,6), $T_C = 25^\circ C$, 50 Ω System

Characteristic	Symbol	Min	Max	Unit
Frequency Range MHW707-1 MHW707-2 MHW707-3 MHW707-4	—	403 440 470 490	440 470 500 512	MHz
Control Voltage ($P_{out} = 7.0 W$, $P_{in} = 1.0 mW$) (1)	V_{Cont}	0	7.0	Vdc
Quiescent Current ($V_{S1} = V_{S2} = V_{S3} = V_{S4} = 7.5 Vdc$, $P_{in} = 0 mW$, $V_{Cont} = 0 Vdc$)	—	—	150	mA
Power Gain ($P_{out} = 7.0 W$, $V_{Cont} = 7.0 Vdc$) (2)	G_p	38.5	—	dB
Efficiency ($P_{out} = 7.0 W$, $P_{in} = 1.0 mW$) (1) (2)	η	40	—	%
Harmonics ($P_{out} = 7.0 W$) (1) (2) ($P_{in} = 1.0 mW$) $2 f_0$	—	—	-40	dBc
Input VSWR ($P_{out} = 7.0 W$, $P_{in} = 1.0 mW$, 50 Ω Ref. (1) (2)	—	—	2.0:1	—
Control Current ($V_{S1} = V_{S2} = V_{S3} = V_{S4} = 7.5 Vdc$, $P_{in} = 1.0 mW$) (1)	—	—	95	mA
Load Mismatch ($V_{S1} = V_{S2} = V_{S3} = V_{S4} = 9.0 Vdc$) VSWR = 10:1, $P_{out} = 9.0 W$, $P_{in} = 3.0 mW$ (1)	—	—	—	No Degradation in Power Output
Stability ($P_{in} = 1.0-3.0 mW$, $V_{S1} = V_{S2} = V_{S3} = V_{S4} = 6.0-9.0 Vdc$) P_{out} between 1.0 W and 9.0 W (1) Load VSWR = 8:1, All Phase Angles	—	—	—	All spurious outputs more than 60 dB below desired signal

NOTES:

1. Adjust V_{Cont} for specified P_{out} .
2. MHW707-4 Specifications: $P_{out} = 7.0 W$ @ 490 MHz
 $P_{out} = 6.5 W$ @ 512 MHz

REV 7

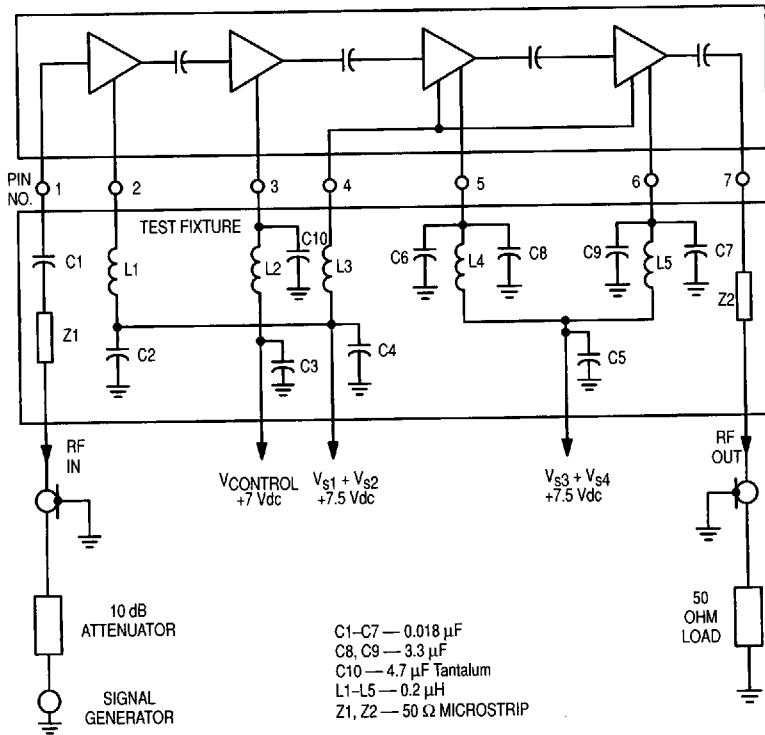

Figure 1. Power Module Test System Block Diagram

TYPICAL CHARACTERISTICS (MHW707-1)

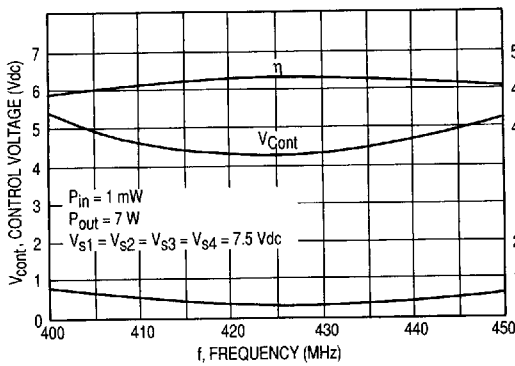

Figure 2. Control Voltage, Efficiency and VSWR versus Frequency

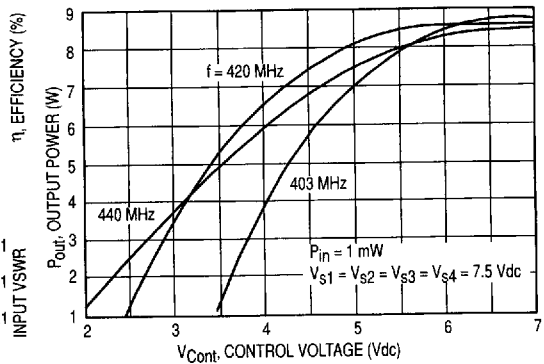

Figure 3. Output Power versus Control Voltage

**TYPICAL CHARACTERISTICS
(MHW707-1)**

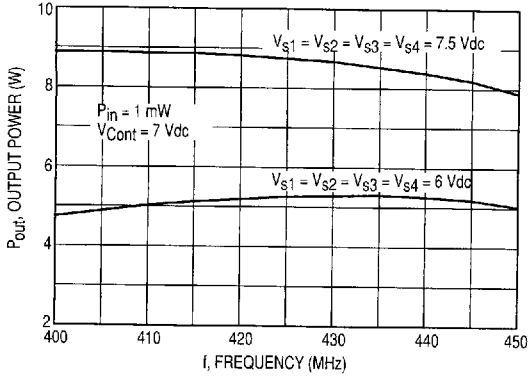

Figure 4. Output Power versus Frequency

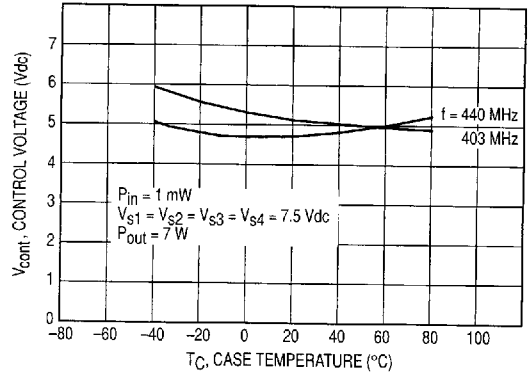

Figure 5. Control Voltage versus Case Temperature

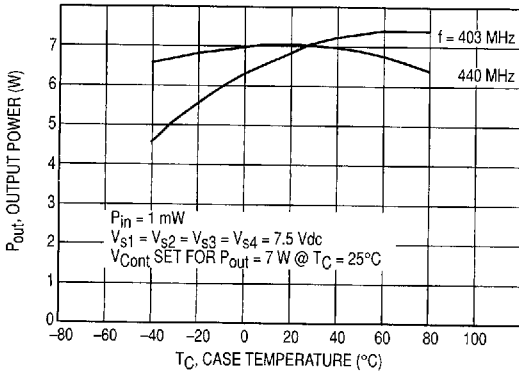

Figure 6. Output Power versus Case Temperature

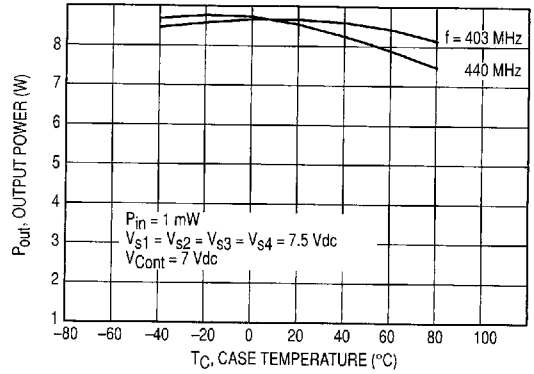

Figure 7. Output Power versus Case Temperature at Maximum Control Voltage

**TYPICAL CHARACTERISTICS
(MHW707-2)**

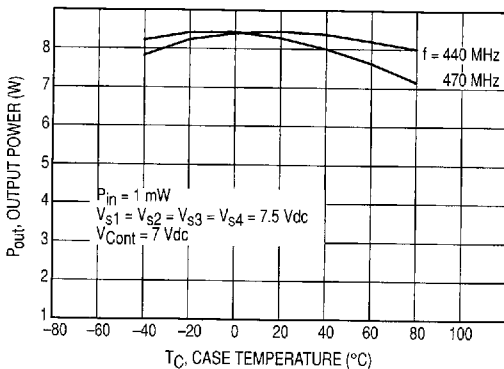

Figure 8. Output Power versus Case Temperature at Maximum Control Voltage

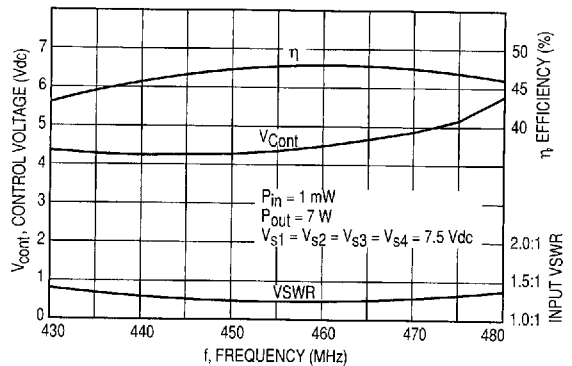

Figure 9. Control Voltage Efficiency and VSWR versus Frequency

TYPICAL CHARACTERISTICS (MHW707-2)

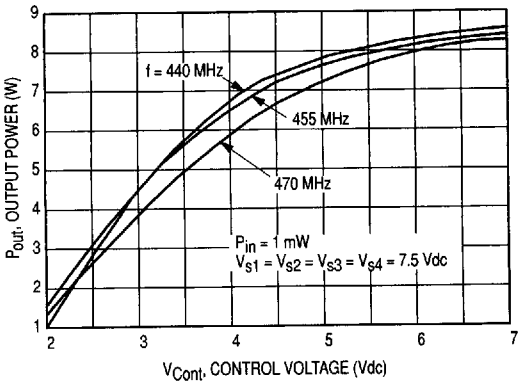

Figure 10. Output Power versus Control Voltage

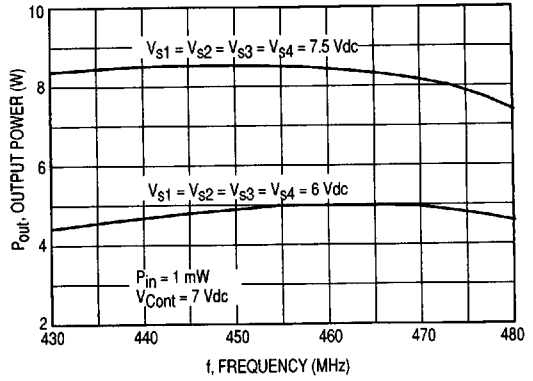

Figure 11. Output Power versus Frequency

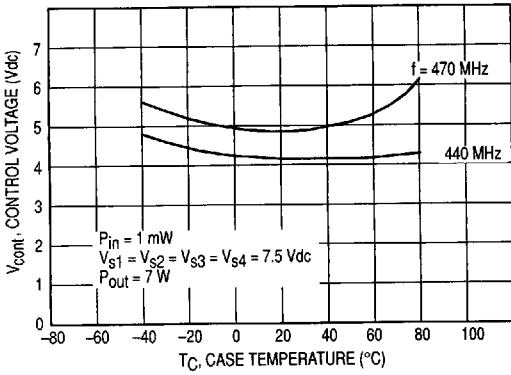

Figure 12. Control Voltage versus Case Temperature

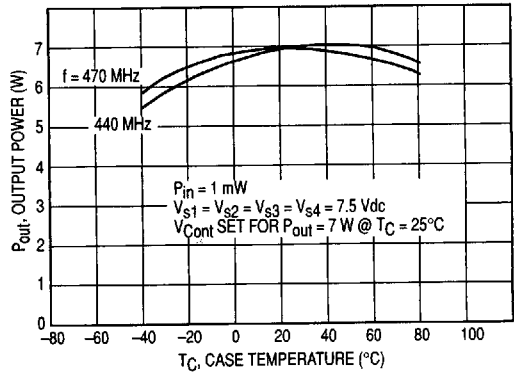

Figure 13. Output Power versus Case Temperature

TYPICAL CHARACTERISTICS (MHW707-3)

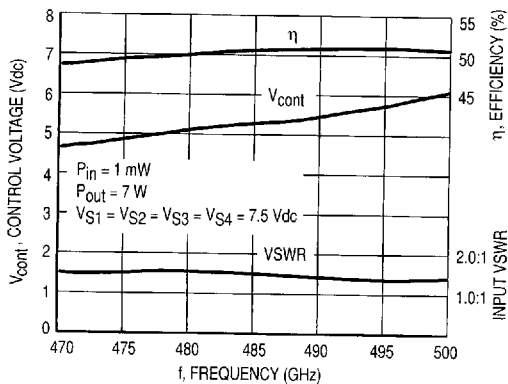

Figure 14. Control Voltage, Efficiency and VSWR versus Frequency

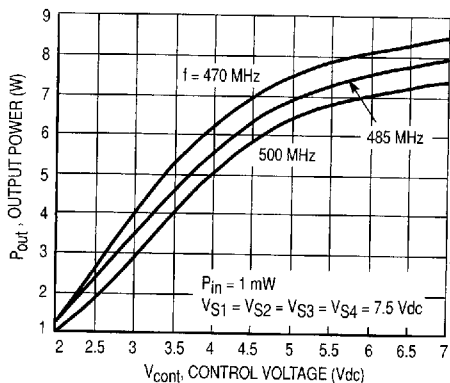

Figure 15. Output Power versus Control Voltage

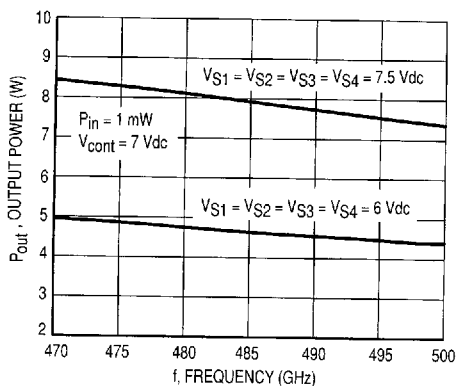

Figure 16. Output Power versus Frequency

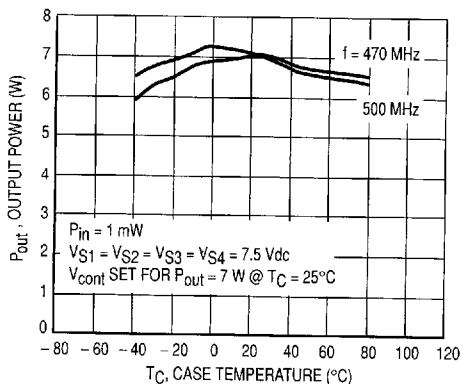

Figure 17. Output Power versus Case Temperature

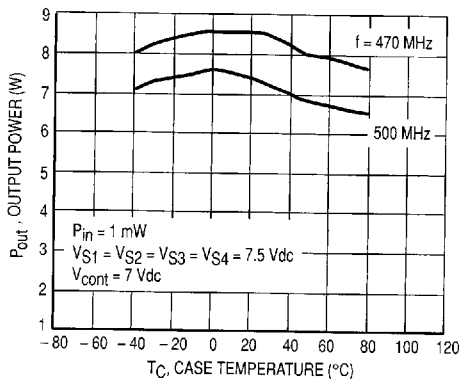

Figure 18. Output Power versus Case Temperature at Maximum Control Voltage

TYPICAL CHARACTERISTICS (MHW707-4)

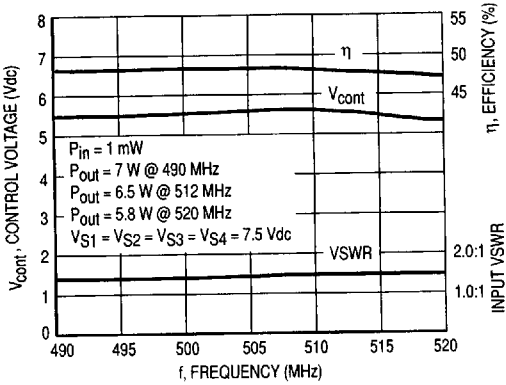

Figure 19. Control Voltage, Efficiency and VSWR versus Frequency

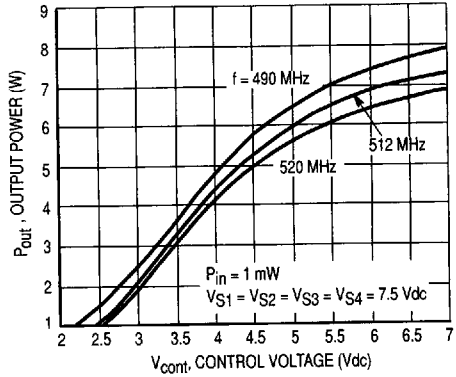

Figure 20. Output Power versus Control Voltage

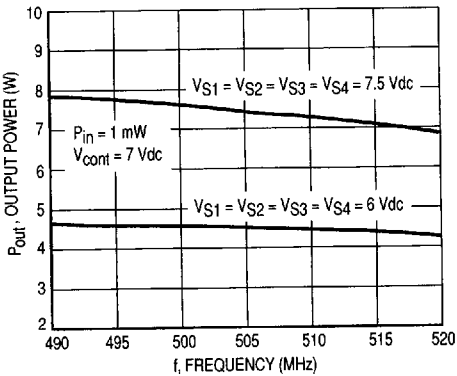

Figure 21. Output Power versus Frequency

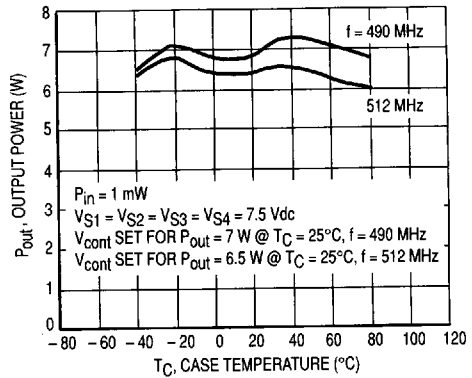

Figure 22. Output Power versus Case Temperature

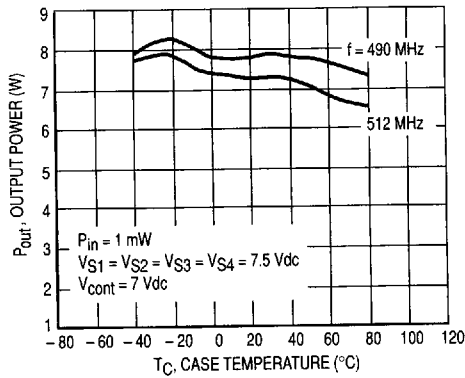

Figure 23. Output Power versus Case Temperature at Maximum Control Voltage

APPLICATIONS INFORMATION

NOMINAL OPERATION

All electrical specifications are based on the nominal conditions of $V_{S1} = V_{S2} = V_{S3} = V_{S4} = 7.5$ Vdc (Pins 2, 4, 5, 6) and P_{out} equal to 7.0 watts (6.5 W for MHW707-4). With these conditions, maximum current density on any device is 1.5×10^5 A/cm². While the modules are designed to have excess gain margin with ruggedness, operation of these units outside the limits of published specifications is not recommended unless prior communications regarding intended use have been made with the factory representative.

GAIN CONTROL

The module output should be limited to 7.0 watts. The preferred method of power output control is to fix $V_{S1} = V_{S2} = V_{S3} = V_{S4} = 7.5$ Vdc (Pins 2, 4, 5, 6), P_{in} (Pin 1) at 1.0 mW, and vary V_{cont} (Pin 3) voltage.

DECOUPLING

Due to the high gain of the four stages and the module size limitation, external decoupling networks require careful consideration. Pins 2, 3, 5 and 6 are internally bypassed with a 0.018 μ F chip capacitor which is effective for frequencies from 5.0 MHz through 940 MHz. For bypassing frequencies below 5.0 MHz, networks equivalent to that shown in Figure 1 are recommended. Inadequate decoupling will result in spurious outputs at certain operating frequencies and certain phase angles of input and output VSWR.

LOAD MISMATCH

During final test, each module is load mismatch tested in a fixture having the identical decoupling networks described in Figure 1. Electrical conditions are $V_{S1} = V_{S2} = V_{S3} = V_{S4}$ equal to 9.0 Vdc, VSWR equal to 10:1, and output power equal to 9.0 watts.